

Jardis
Industries, Inc.

Festoon Splicers

Increase Profits

Cut Makeready Waste

Save on Running Waste

Salvage Butt Rolls

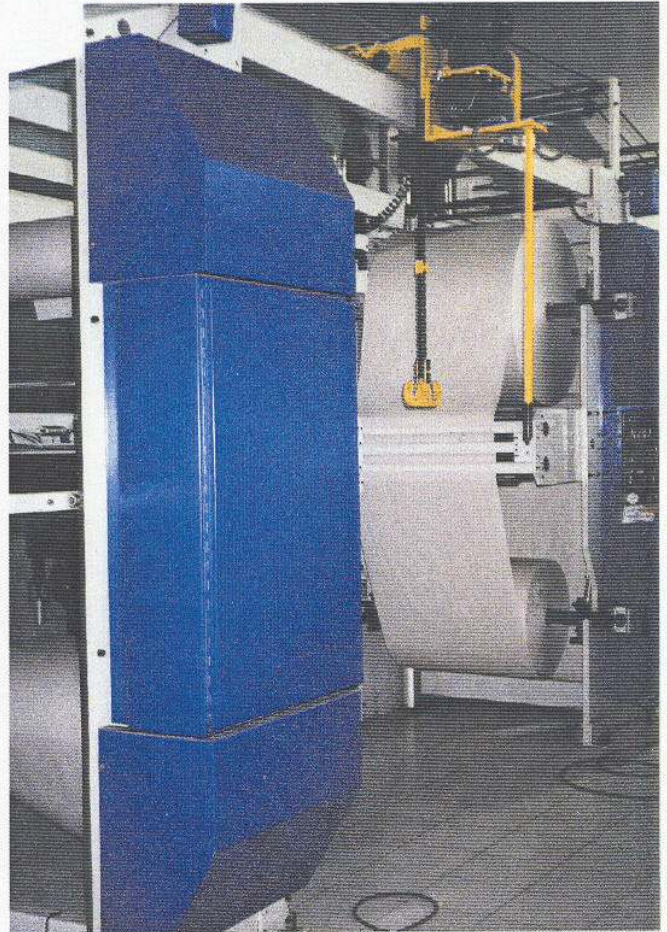

Reliable, Accurate Web Splicing

Festoon splicers from Jardis Industries provide fully automatic paper roll splicing and improved web tension necessary for modern high speed printing presses. A low inertia air loaded festoon acts as a tension control and storage system during new reel acceleration at time of splice. Simple splice preparation and exceptional splice accuracy results in improved operating efficiency, increased profits, and reduction of waste.

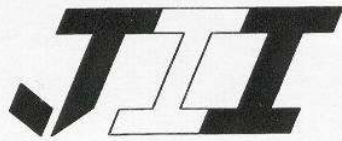

JARDIS INDUSTRIES, INC.

MODEL ZS-5040 FESTOON SPLICER

FEATURES

- OPTIONAL PRESS DRIVEN AUTOMATIC INFEED
- ONE BUTTON CHANGE FOR FULL OR PARTIAL ROLLS
- MOTORIZED SIDELAY
- DUAL UNWIND CAPACITY
- AIR COOLED BRAKES
- EASY INSTALLATION AND STARTUP
- MINIMUM OPERATOR ADJUSTMENTS
- MINIMUM CORE DIAMETER ADJUSTMENT
- NO PRESS CONNECTIONS – MECHANICAL OR ELECTRICAL
- QUICK DISCONNECT CORESHAFT, AUTOMATICALLY DISENGAGES
- SIMPLE, ROUTINE MAINTENANCE
- FULL DIAGNOSTICS
- DIGITAL AUTO-SPLICE
- AUTO WEB ACCELERATION
- ALL LOGIC ON ONE PC BOARD
- DUAL UNWIND WITH INDEPENDENT BRAKE CONTROL-OPTION
- AIR-LOADED FESTOON TENSION SYSTEM RIDES LOW UNTIL SPLICING

SPECIFICATIONS

- MAXIMUM ROLL WEIGHT 3000 lbs.
- MAXIMUM WEB WIDTH 40"
- MAXIMUM ROLL DIAMETER 50"
- MINIMUM WEB WIDTH 10.5"
- MAXIMUM SPLICING SPEED 1600 F.P.M.
- MINIMUM SPLICING SPEED 0 F.P.M.
- MAXIMUM TENSION 60 lbs. total
- MINIMUM TENSION 10 lbs. total
- SIDELAY ± .75" (3/4")
- ELECTRICAL REQUIREMENTS 220/440,3 phase
4 KVA (intermittent)
- PNEUMATIC REQUIREMENTS 2 SCFM
100 PSI (intermittent)
- EMERGENCY STOP RATE 600 FPM/sec.
(normal splicing mode) with 3000 lb. roll

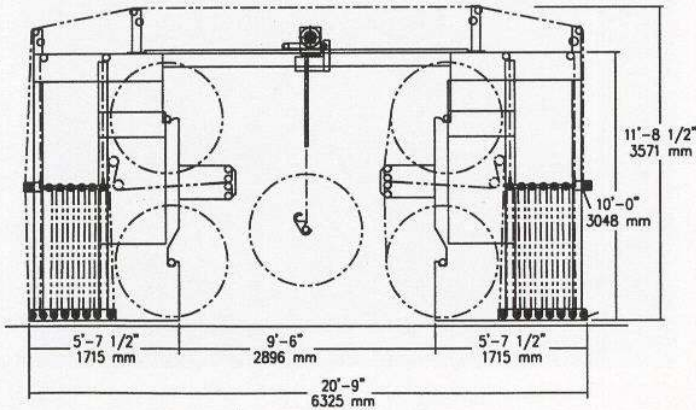

NORMAL SPACE REQUIREMENTS, TANDEM SPLICERS WITH HOIST

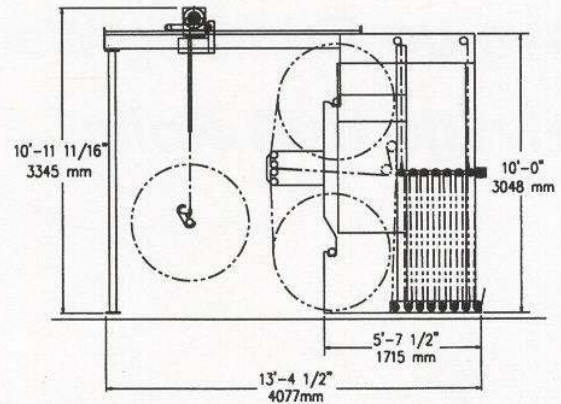

NORMAL SPACE REQUIREMENTS, SINGLE SPLICER WITH HOIST

NOTE: SPECIFICATIONS SUBJECT TO CHANGE WITHOUT NOTICE

Jardis Industries, Inc.

1201 Ardmore ■ Itasca, IL 60143

630-860-5959 ■ Fax 630-860-6515